

Beautilities

*Lamps*

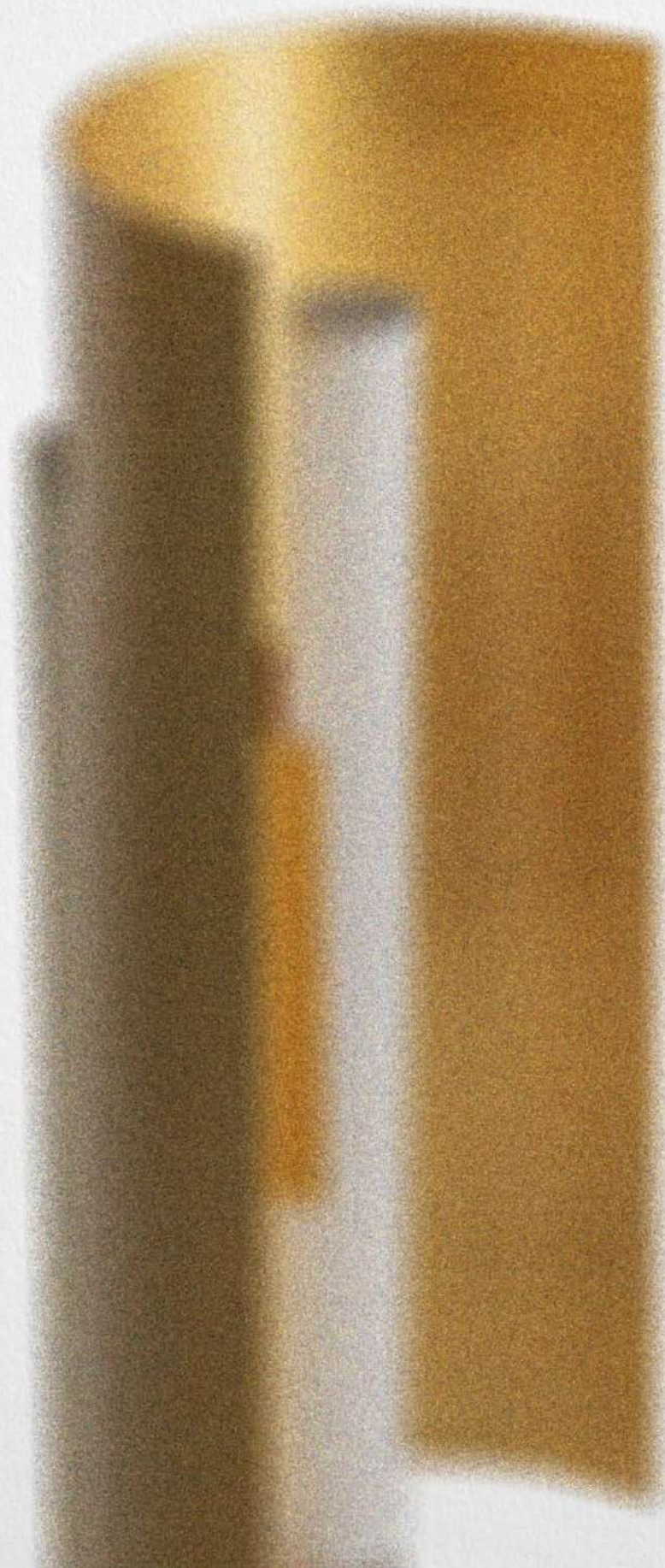



# Poltrona Frau *Lamps* Main Index

**LAMPS**

Alma	6
Dido	10
Fede	14
Fidelio lamp	18
Foliage	24
Gio Ponti Oro	28
Holly	34
Moonbeam	38
Nymph	48
Soffi	62
Sparkler	70
Tullissè	78
Xi	84
<b>Translations and Technical Drawings</b>	<b>95</b>

# Lamps



6 Alma



10 Dido



14 Fede

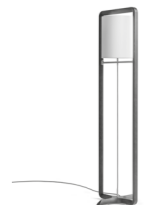

18 Fidelio Lamp



24 Foliage



28 Gio Ponti Oro



34 Holly



38 Moonbeam



48 Nymph



62 Soffi



70 Sparkler



78 Tullissè



84 Xi

Designed by Jean-Marie Massaud and handcrafted exclusively by Murano's master glassblowers, Alma is a luminous sculpture that plays on transparency.

Two ribbed glass bells overlap to form a glowing hourglass, in which time seems suspended. The purity of the blown glass diffuses a warm, enveloping light - perfect for enriching contemporary living spaces with poetry and balance.

# Alma

Jean-Marie Massaud





Defined by elegance and restraint, the Dido table lamp, designed by Jean-Marie Massaud and crafted in transparent glass by Murano's masters, presents a refined, minimalist presence.

Its oval base supports a round shade available in three tones. A discreet yet authoritative presence, capable of elevating any space with its soft, sophisticated light.

# Dido

Jean-Marie Massaud

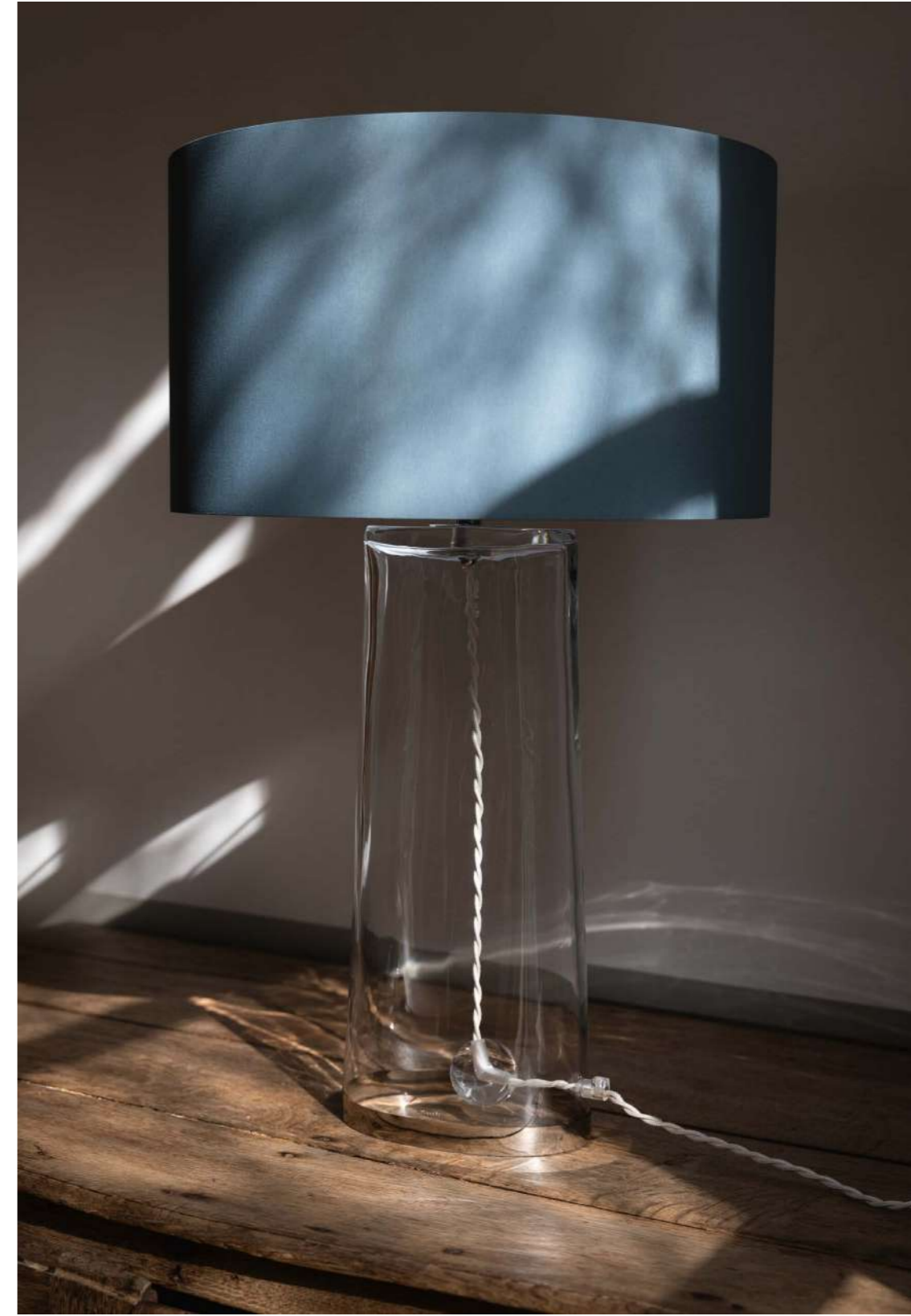

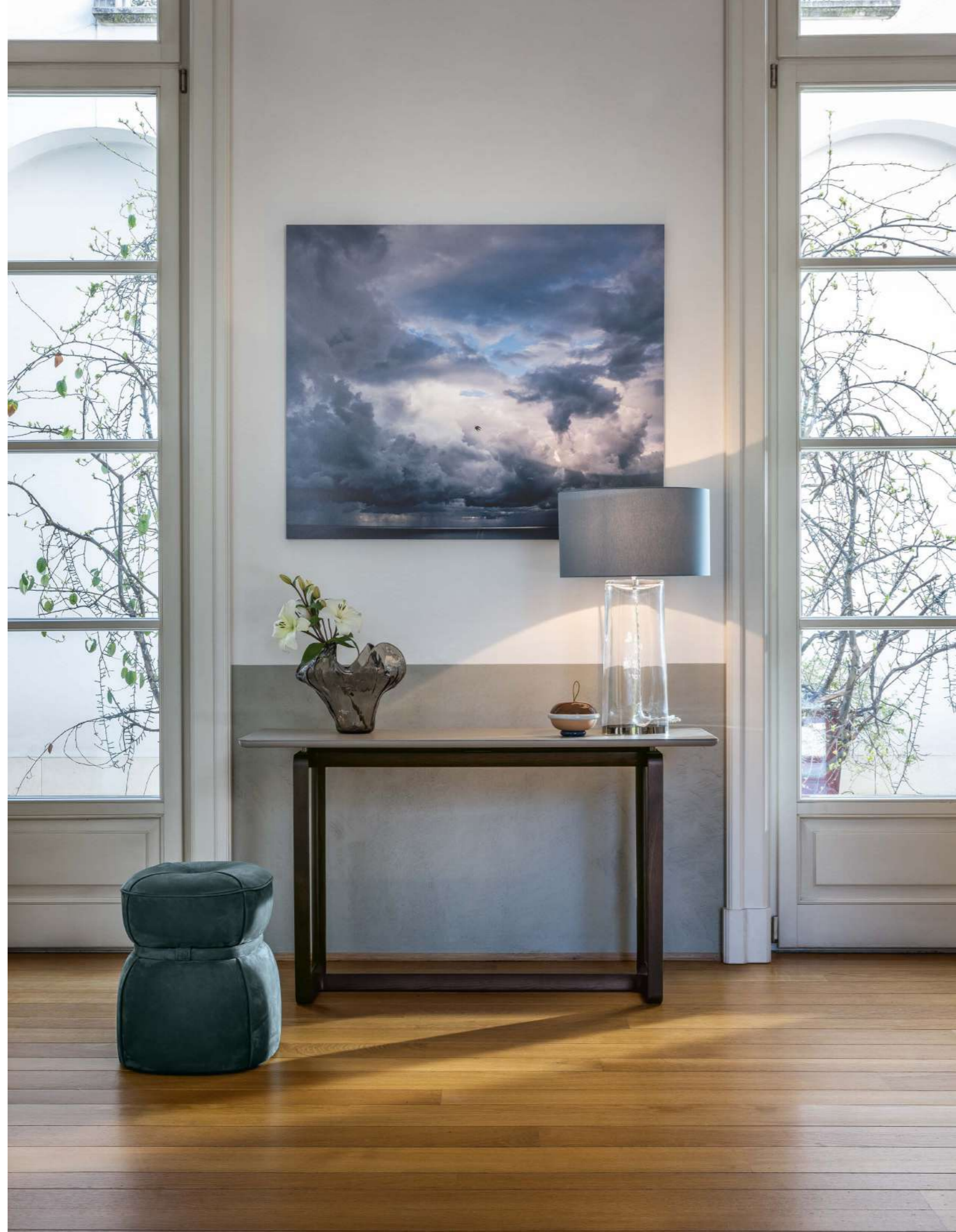

The Fede floor lamp interprets light as a piece of jewelry. Along the painted metal stem, a precious necklace of transparent glass bubbles - blown by Murano's master artisans - intertwines.

The round shade, offered in three color options, diffuses a warm, refined luminosity. A work of art that fuses sculpture and function in perfect balance.

# Fede

Jean-Marie Massaud





The linear and understated elegance of the Fidelio collection also finds expression in the floor lamp designed by Roberto Lazzeroni, conceived to live in perfect harmony with sofas and armchairs.

# Fidelio Lamp

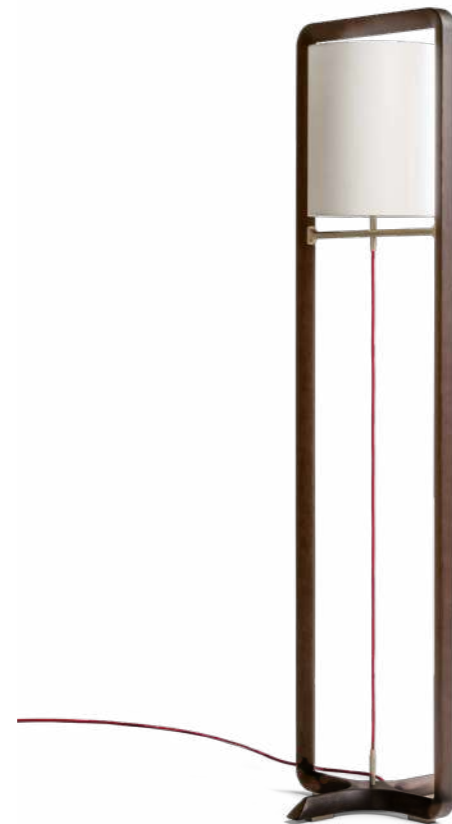

Roberto Lazzeroni

A discreet yet sophisticated presence that defines living spaces of greater comfort and versatility. Its vertical architecture celebrates purity of proportion and the millimetric precision of its lines, revealing the natural beauty of its materials.

Crafted from solid ash wood with a triangular section and available in a range of finishes, Fidelio traces a pure geometric form — a simple rectangle that naturally embraces the light source. The lampshade features a double-layer construction, with an outer fabric and inner PVC lining, while metal details in brushed steel with a natural brass finish complete the composition with a touch of refined elegance.







Designed by Six N. Five, the Foliage floor lamp features a brass base from which a stylized “tree” rises, also made of brass, with leaves upholstered in Pelle Frau® leather.

# Foliage



Six N. Five

An innovative lighting system, developed specifically by Poltrona Frau, emits light from below to create the illusion of a leaf “silhouette” that gently reverberates across the surrounding walls. When illuminated, the sculpture seems to dematerialize, transforming into shadow and giving life to a poetic, warm, and enveloping atmosphere.

Six N. Five is the studio founded by Argentine digital artist and designer Ezequiel Pini, a pioneer in the artistic use of 3D imagery. His creative vision is deeply connected to the exploration of nature and light. This collaboration with Poltrona Frau marks his first venture into the world of lighting design.



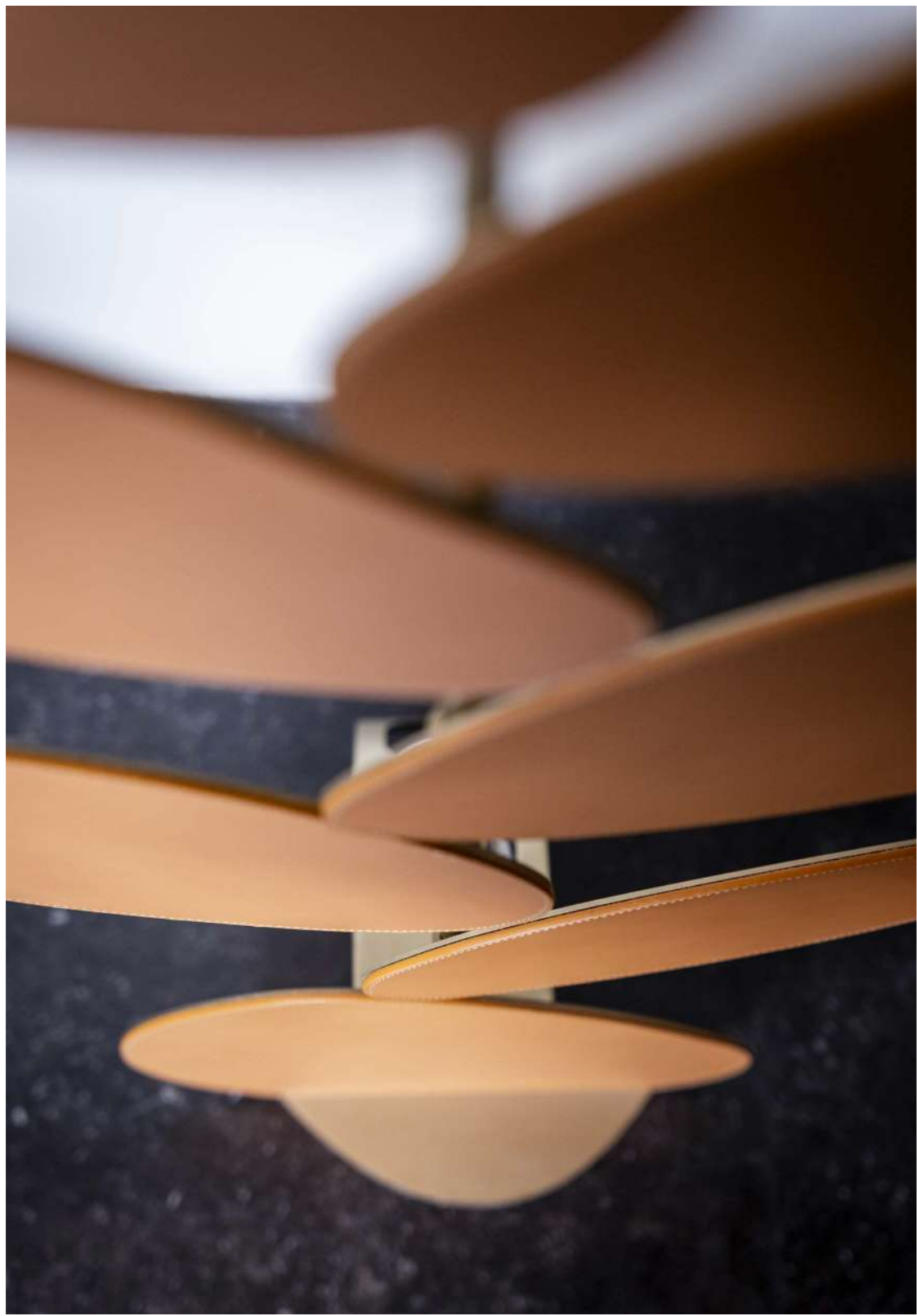

More than a reissue, a true rediscovery: Gio Ponti Oro is a floor lamp designed by the Master in the 1950s for a residential project and never put into production.

# Gio Ponti Oro



Today it is brought to light by Poltrona Frau in collaboration with the Gio Ponti Archives, as part of the "True Over Time" collection, dedicated to authentic design that endures over time.

Defined by a strong sculptural presence, the lamp stands out for its refined balance between form and light. Curved metal panels, arranged in a rhythmic sequence, interact with the vertical light tubes to create a dynamic, three-dimensional effect. The satin brass finish lends timeless elegance, enhancing the contrast between matte surfaces and luminous elements.

A project that embodies Gio Ponti's timeless vision and the enduring relevance of a design that remains strikingly modern across decades.

Gio Ponti







Designed by Jean-Marie Massaud and handcrafted by Murano's master glassblowers, Holly stands out with its soft, sinuous lines evoking a stylized female profile.

The transparent glass base interacts with elements in painted metal and burnished brass, creating a harmonious and refined whole.

Available as both a table lamp and a floor lamp, Holly emanates an elegant, embracing light through its double-layered shade (outer layer in fabric, inner in PVC). In its floor version, it is offered with either a single or double shade, allowing you to modulate the light's intensity and presence depending on the space and desired ambiance.

# Holly

Jean-Marie Massaud





The celestial Moonbeam table lamp creates the illusion of a solar eclipse. A poetic piece of moonlight that softly illuminates the room with a gentle, dim glow.

Moonbeam, designed by Six N. Five for Poltrona Frau, is a luminous sculpture that captures the natural rhythm and mystery of the moon's changing phases, creating an intimate and enchanting atmosphere. A truly unique design table lamp.

Reinterpreting the concept of an eclipse in an entirely original way, the lamp features a disc covered in Pelle Frau® leather, available in a selection of colors, resting on a rectangular brass base. The disc partially overlaps a larger luminous circle made of frosted glass, forming a suspended slice of light reminiscent of a lunar crescent. The result is one of great emotional impact – a poetic, relaxing glow that fills the space with quiet elegance.

# Moonbeam

Six N. Five





The poetic essence of Moonbeam, winner of the Wallpaper\* Design Awards 2026, expands into two new versions: an enlarged table lamp and a new floor variant.

The new table version enhances its sense of refinement, while the floor lamp — ideal behind a sofa — creates the impression of light suspended in space, like a small floating moon. Refined proportions and detailing heighten its theatrical effect, reinforcing the collection' sophisticated identity. All the Moonbeam lamps feature a brass finish, with a disc available in brass or Pelle Frau® ColorSphere® Impact Less leather in Latte, Tortora, Mattone and Darsena







Nymph is inspired by the eponymous female deities from ancient Greek mythology, benevolent personifications of nature at the service of human beings. Inspired by the concept of a gentle presence that accompanies our daily life, this blown glass lamp with a delicately-pleated lampshade floats weightlessly on its leather-covered base.

# Nymph

As a tribute to the classic leather tufted button on Poltrona Frau upholstery, the on/off and dimmer switch is designed as a brass button embedded in the lampshade base. When switched on, the illumination transforms the design object into a graceful incandescent sculpture, reminiscent of gentle ethereal maiden. Available in Pearl and Fumé finishes, the blown glass lampshade is a single cylinder shape with vertical bevelled ribbing that creates a unique visual illumination effect.

This is covered in Pelle Frau® ColorSphere® available in a choice of colors offset with contrasting stitching and metallic brass details. The lamp has an on/off touch button dimmer switch.

Sebastian Herkner











The collection is now expanded with a new pendant version: Nymph Air. This new interpretation preserves the project's distinctive features: the fluted glass, inspired by one of Poltrona Frau's signature techniques, and the "button" detail applied to the lower part of the diffuser, recalling the iconic tufting of the Chester sofa. In this version, a high-efficiency LED light bar interacts with the glass, casting a uniform, soft and enveloping light enriched by subtle transparencies. The effect is further enhanced by the introduction of a new white gradient glass, designed to create an even more evocative atmosphere. The lighting body is completed by a height-adjustable suspension system, allowing for versatile integration in both residential and contract settings.





Soffi. The purity of light and glass blown by Venice's master craftsmen. The minimalistic design of GamFratesi captures the exact moment when the blowing technique gives the glass its shape. Delicate and irregular globes seem to float out of a slender leather arm suspended in the air by the force of gravity.

# Soffi



GamFratesi

The project is inspired by an ancient art translated into a simple yet contemporary language.

Each lamp is unique: subtle differences in tone and irregular shapes created by blowing different colours of glass.

The lamps are available in three sizes, small, medium and large, which can be arranged in a range of configurations. As well as an individual lamp, the design can also be arranged in linear compositions of three globes or hanging arrangements with three or five globes.









Sparklers come in three sizes. They are made of a basalt-coloured powder-coated aluminium frame, on which a 0.5mm round polypropylene cord is hand-woven in taupe.

# Sparkler

The spotlight - a LED with an 8W lithium battery, rechargeable via USB cable - is concealed in the 2cm thick top, which has a horseshoe-shaped handle making it easy to move around. The spotlight is also equipped with an innovative safety system to prevent accidental unscrewing.

A 250cm long, flat cable with an automatic safety catch at the end allows the lantern to be hung from the ceiling or the beam of a pergola. A 130 cm high arch support transforms the floor lamp into a curved luminaire. Two simple accessories that multiply the possibilities of use by changing the perception of the product: from a floor element to more vertical and airy structures.

Jean-Marie Massaud









The Tullissè table lamp is the result of a new collaboration with Atelier Oi. The result is both sophisticated and ethereal, reminiscent of the tulle tutu of a classical ballerina, which inspires the name Tullissè.

# Tullissè



Atelier Oi

The Swiss multidisciplinary studio marks its first project with Poltrona Frau, reinterpreting the concept of the abat-jour in a contemporary way through an object that explores the interplay of light and shadow, expressing a new material and luminous language.

A refined spiral weave of Pelle Frau® leather strips forms a modern and distinctive lampshade, diffusing a soft, enveloping light. The leather shade rests on a structural glass element crafted using an artisanal technique: white at the top, it gradually fades into transparency towards the base, enhancing a captivating sense of lightness and magic. The lamp base is made of aluminium with a brass-painted finish.

The lamp is available in two sizes and three colour combinations: red (Lacca/Smoked Quartz), brown-grey (India/Smoked Quartz), and blue-light blue (Atlantic Blue/Bardiglio).

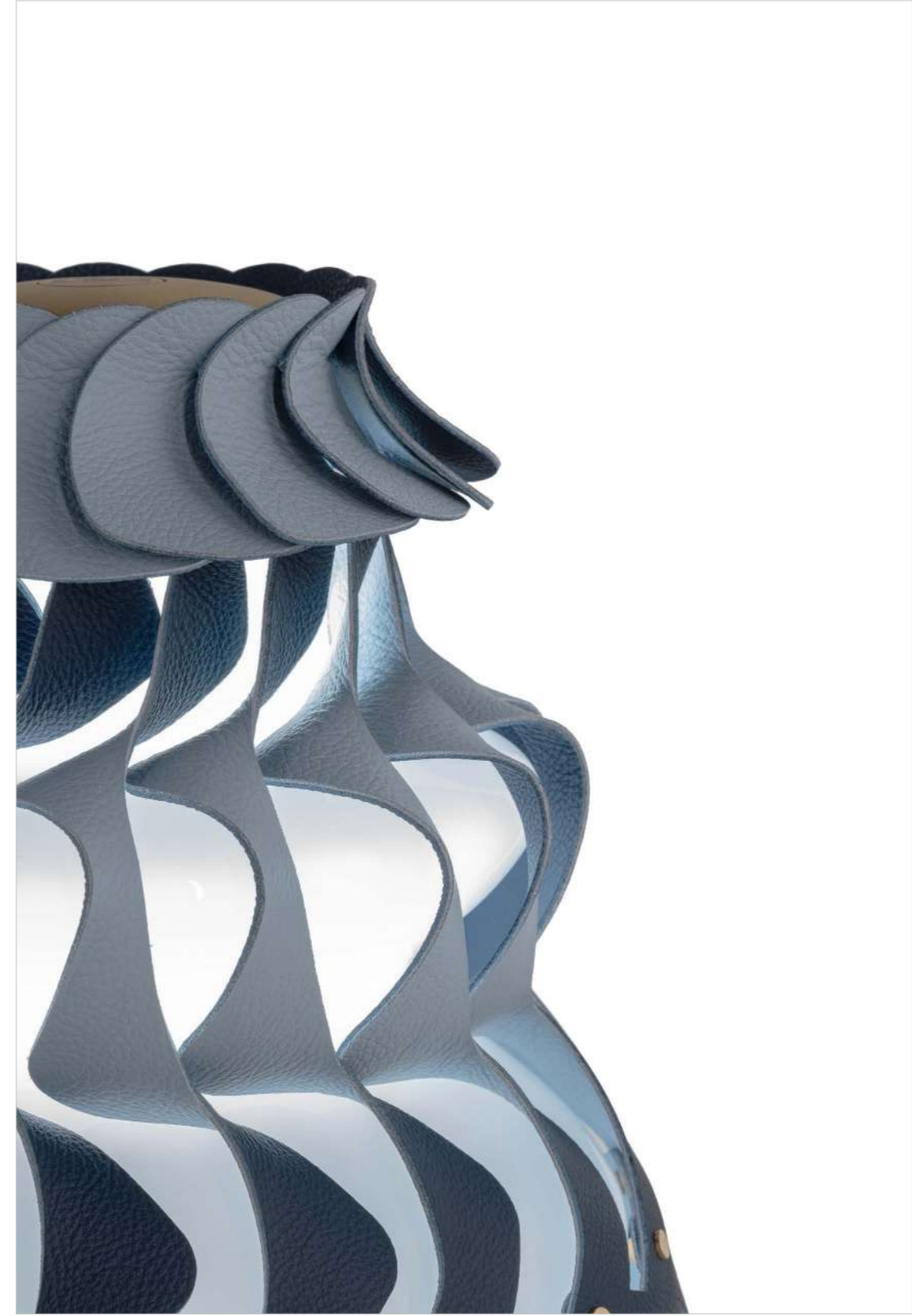





In Chinese Xi means “light of dawn”, but also “in praise of wisdom”. And when the lamps designed by Neri&Hu are illuminated, their soft, full light evokes the early morning sunlight. The project aims to convey a culture of light based on the awareness that the start of any day is like the beginning of life, infused with positivity and a sense of rebirth.

The Xi lamps made of blown glass and saddle-leather are lulled by space, like lanterns: a mysterious and suggestive presence. This light and essential contemporary design combines traditions of an eastern flavour with the leather culture of Poltrona Frau and skilful Venetian masters’ art of blown glass. The Xi collection consists of two hanging lamps, one small and one large, and a table lamp.

The luminaire emanates pure lines and a delicate contrast of materials, bringing together two elements in blown glass. The upper glass has a particular evenly ridged surface and is transparent in shades amber, emerald, sapphire or moon stone. The lower glass is etched with a pearl finish, for a warm and diffused light. In the hanging version, a band of Cuoio Saddle Extra leather hugs the luminaire and supports it like a trapezoid or a delicate lantern.

# Xi

Neri&Hu



The lamps are installed on a suspended horizontal bar, which is adjustable in height. The track structure of the bar makes it possible to move the lamps horizontally and fix them in the desired position. The system is available in several combinations of single or multiple lamps.







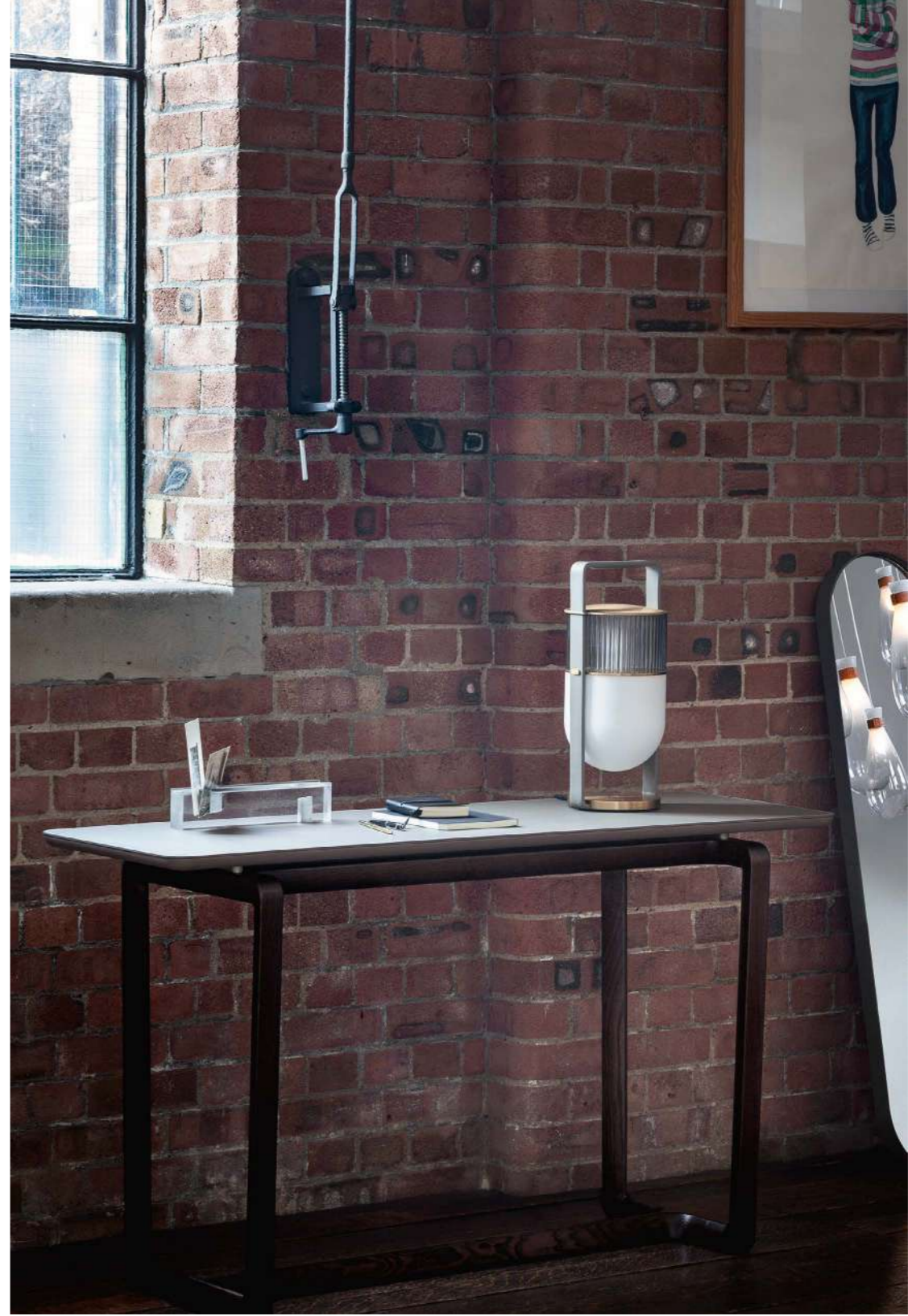



# Poltrona Frau *Lamps* Translations and technical drawings

IT

Le Lampade di Poltrona Frau

**ALMA**

Progettata da Jean-Marie Massaud e realizzata a mano in esclusiva dai maestri vetrai di Murano, Alma è una scultura luminosa che gioca con la trasparenza. Due campane in vetro rigato si sovrappongono formando una clessidra luminosa, in cui il tempo sembra sospeso. La purezza del vetro soffiato diffonde una luce calda e avvolgente, perfetta per arricchire gli interni contemporanei con poesia ed equilibrio.

**DIDO**

Definita da eleganza e misura, la lampada da tavolo Dido, disegnata da Jean-Marie Massaud e realizzata in vetro trasparente dai maestri di Murano, presenta una presenza raffinata e minimalista. La sua base ovale sostiene un paralume rotondo disponibile in tre tonalità. Un oggetto discreto ma autorevole, capace di elevare qualsiasi ambiente con la sua luce morbida e sofisticata.

**FEDE**

La lampada da terra Fede interpreta la luce come un gioiello. Lungo lo stelo in metallo verniciato si intreccia una preziosa collana di bolle in vetro trasparente, soffiate a mano dai maestri artigiani di Murano. Il paralume rotondo, proposto in tre varianti cromatiche, diffonde una luminosità calda e raffinata. Un'opera d'arte che fonde scultura e funzione in un equilibrio perfetto.

**FIDELIO LAMP**

L'eleganza lineare ed essenziale della collezione Fidelio trova espressione anche nella lampada da terra disegnata da Roberto Lazzeroni, pensata per vivere in perfetta armonia con divani e poltrone. Una presenza discreta ma sofisticata, capace di definire spazi living all'insegna del comfort e della versatilità. La sua architettura verticale celebra la purezza delle proporzioni e la precisione millimetrica delle linee, rivelando la naturale bellezza dei materiali. Realizzata in massello di frassino con sezione triangolare e disponibile in diverse finiture, Fidelio delinea una forma geometrica pura — un semplice rettangolo che accoglie naturalmente la fonte luminosa. Il paralume presenta una struttura a doppio strato, con tessuto esterno e interno in PVC, mentre i dettagli metallici in acciaio spazzolato con finitura in ottone naturale completano la composizione con un tocco di raffinata eleganza.

**FOLIAGE**

Disegnata da Six N. Five, la lampada da terra Foliage presenta una base in ottone da cui si innalza un "albero" stilizzato, anch'esso in ottone, con foglie rivestite in

Pelle Frau®. Grazie a un innovativo sistema di illuminazione, sviluppato da Poltrona Frau, la luce emessa dal basso crea l'illusione di una "silhouette" fogliare che si riflette dolcemente sulle pareti circostanti. Una volta accesa, la scultura sembra smaterializzarsi, trasformandosi in ombra e dando vita a un'atmosfera poetica, calda e avvolgente. Six N. Five è lo studio fondato dal designer e artista digitale argentino Ezequiel Pini, pioniere nell'uso artistico delle immagini 3D. La sua visione creativa è profondamente legata all'esplorazione della natura e della luce. Questa collaborazione con Poltrona Frau segna il suo primo progetto nel mondo del lighting design.

**GIO PONTI ORO**

Più che una riedizione, una vera e propria riscoperta: Gio Ponti Oro è una lampada da terra progettata dal Maestro negli anni '50 per un progetto residenziale e mai entrata in produzione. Oggi viene riportata alla luce da Poltrona Frau in collaborazione con Gio Ponti Archives, all'interno della collezione "True Over Time", dedicata a un design autentico e capace di attraversare il tempo. Caratterizzata da una forte presenza scultorea, la lampada si distingue per l'equilibrio raffinato tra forma e luce. I pannelli metallici curvi, disposti in sequenza ritmica, dialogano con i tubi luminosi verticali creando un effetto dinamico e tridimensionale. La finitura in ottone satinato conferisce eleganza e profondità, esaltando il contrasto tra superfici opache e sorgenti luminose. Un progetto che testimonia la visione senza tempo di Gio Ponti e il valore di un design che, anche a distanza di decenni, conserva intatta la propria modernità.

**HOLLY**

Disegnata da Jean-Marie Massaud e realizzata a mano dai maestri vetrai di Murano, Holly si distingue per le linee morbide e sinuose che evocano un profilo femminile stilizzato. La base in vetro trasparente dialoga con elementi in metallo verniciato e ottone brunito, dando vita a un insieme armonioso e raffinato. Disponibile sia nella versione da tavolo che da terra, Holly diffonde una luce elegante e avvolgente attraverso il paralume a doppio strato — con rivestimento esterno in tessuto e interno in PVC. Nella versione da terra è proposta con paralume singolo o doppio, per modulare intensità e presenza della luce in base allo spazio e all'atmosfera desiderata.

**MOONBEAM**

La poesia di Moonbeam, vincitrice dei Wallpaper\* Design Awards 2026, si estende a due

nuove versioni, una da tavolo di dimensioni maggiorate e una nuova variante da terra. Nata dalla collaborazione con l'artista digitale Six N. Five (Ezequiel Pini) e presentata alla Milano Design Week 2025, la collezione si arricchisce con una lampada da tavolo Large e una versione da terra, ampliando le possibilità d'uso in contesti residenziali e contract.

Ispirata alla luna e alle sue fasi, Moonbeam si distingue per il suo carattere evocativo e scultoreo. La nuova versione da tavolo ne accentua la preziosità, mentre la lampada da terra — ideale dietro un divano — crea l'effetto di una luce sospesa, come una piccola luna in equilibrio nello spazio. Proporzioni e dettagli ricercati esaltano l'effetto scenografico, rafforzando il carattere sofisticato della collezione.

Sia la versione da tavolo che quella da terra, sono in finitura ottone, con disco disponibile in ottone o in Pelle Frau® ColorSphere Impact Less nelle tonalità Latte, Tortora, Mattone e Darsena.

**NYMPH**

Ispirata alle ninfe della mitologia greca, benevoli spiriti della natura, Nymph è una lampada in vetro soffiato che sembra fluttuare leggera sulla sua base rivestita in Pelle Frau® ColorSphere®. Il paralume plissettato, disponibile nelle finiture Perla e Fumé, diffonde una luce morbida e avvolgente, trasformando l'oggetto in una scultura luminosa e poetica. Un elegante bottone in ottone alla base, omaggio al classico capitonné Poltrona Frau, funge da interruttore touch con dimmer, per modulare l'intensità della luce con un semplice gesto. Nymph accompagna la quotidianità con grazia, leggerezza e fascino senza tempo.

**NYMPH AIR**

Nymph by Sebastian Herkner è una luce sospesa tra eleganza e leggerezza. Presentata nel 2024, la serie di lampade Nymph si distingue fin da subito per il suo equilibrio misurato tra raffinatezza e semplicità. La collezione si arricchisce oggi di una nuova versione a sospensione: Nymph Air. Questa nuova interpretazione mantiene intatti i tratti distintivi del progetto: il vetro lavorato a canneté, ispirato a una delle lavorazioni iconiche di Poltrona Frau, e il dettaglio del "bottone" applicato nella parte inferiore, che richiama la tradizionale impuntura del divano Chester.

In questa configurazione, una barra LED ad alta efficienza dialoga con il vetro, diffondendo una luce uniforme, morbida e avvolgente, ricca di trasparenza. L'effetto è ulteriormente esaltato dall'introduzione di un

nuovo vetro sfumato bianco, pensato per rendere l'atmosfera ancora più suggestiva. Il corpo illuminante è completato da un sistema di sospensione regolabile in altezza, che consente un'integrazione versatile in ambienti residenziali e contract. La lampada a sospensione Nymph Air è disponibile in due finiture — vetro fumé e vetro sfumato bianco — e in due dimensioni.

**SOFFI**

La purezza della luce e del vetro soffiato dai maestri artigiani veneziani.

Il design minimalista di GamFratesi cattura l'esatto istante in cui la tecnica della soffiatura dona forma al vetro. Globes delicati e irregolari sembrano fluttuare da un esile braccio rivestito in pelle, sospesi nell'aria come mossi dalla forza di gravità.

Il progetto si ispira a un'arte antica, reinterpretata in un linguaggio semplice e contemporaneo.

Ogni lampada è un pezzo unico, con leggere variazioni di tono e forme irregolari, create soffiando vetri di colori differenti.

Le lampade sono disponibili in tre dimensioni — piccola, media e grande — componibili in diverse configurazioni. Oltre alla versione singola, il design è proposto anche in composizioni lineari da tre globi o in sospensioni con tre o cinque globi, per creare scenografie luminose di grande poesia.

**SPARKLER**

Le Sparkler si presentano in tre dimensioni. Sono realizzate con un telaio in alluminio verniciato a polveri color basalto, su cui viene intrecciata a mano una corda in polipropilene a sezione circolare da 0,5mm color taupe. Il corpo illuminante — un led con batteria a litio 8W, ricaricabile tramite cavo USB — è nascosto nei 2cm di spessore della parte sommitale, dotata di maniglia a ferro di cavallo che lo rende facile da movimentare. Il corpo illuminante è anche dotato di un innovativo sistema di sicurezza che ne evita lo svitamento accidentale. Una treccia piatta e lunga 250cm, dotata di sicura automatica all'estremità, consente di appendere la lanterna al soffitto o alla trave di una pergola. Mentre un supporto ad arco dall'altezza di 130cm trasforma la lampada da terra in una piantana. Due semplici accessori che moltiplicano le possibilità d'uso cambiando la percezione del prodotto: da elemento a terra a strutture più verticali e ariose.

**TULLISSÈ**

La lampada da tavolo Tullissè nasce da una nuova collaborazione con Atelier 01. Lo studio svizzero multidisciplinare firma il suo primo progetto per Poltrona Frau, reinterpretando l'idea di abat-jour in chiave

contemporanea attraverso un oggetto che esplora il rapporto tra luce e ombra, dando vita a un inedito linguaggio materico e luminoso. Un raffinato intreccio a spirale di strisce di Pelle Frau® dà forma a un paralume moderno e originale, capace di diffondere una luce morbida e avvolgente. Il paralume in pelle si posa su un vetro strutturale realizzato con una tecnica artigianale: bianco nella parte superiore, sfuma progressivamente verso la trasparenza, amplificando un suggestivo effetto di leggerezza e magia. La base è in alluminio con finitura verniciata ottone. Il risultato è al tempo stesso sofisticato ed etereo, evocando il tutù in tulle di una ballerina classica, da cui prende ispirazione il nome Tullissè.

La lampada è disponibile in due dimensioni e in tre varianti colore: rosso (Lacca/Quarzo Fumé), marrone-grigio (India/Quarzo Fumé) e blu-azzurro (Atlantic Blue/Bardiglio).

## Xi

Xi in cinese significa "luce dell'alba", ma anche "lode della saggezza". E quando le lampade Xi, disegnate da Neri & Hu per Poltrona Frau si accendono, la loro luce morbida e piena evoca il chiarore solare del primo mattino. Il progetto vuole comunicare una cultura della luce fondata sulla consapevolezza che l'inizio di ogni giornata è come l'inizio della vita, permeato di positività e di un senso di rinascita. Le lampade Xi, di vetro soffiato e cuoio, si lasciano cullare dallo spazio come lanterne. Il corpo illuminante accosta due elementi in vetro soffiato. Il vetro superiore, dalla particolare superficie cannettata regolare, è trasparente e colorato nei toni ambra, smeraldo, zaffiro o Pietra di luna. Il vetro inferiore bianco perla, rende la luce calda e diffusa. Sono pezzi unici ottenuti per soffiatura dai Mastri vetrai di Venezia con l'utilizzo di vetri colorati in pasta. Il corpo illuminante è sostenuto da una fascia di cuoio Saddle Extra, disponibile nelle due finiture Cammello e Talpa, con bordo a taglio netto tinto tono su tono e logo Poltrona Frau impresso a caldo. Nelle nuove versioni da terra e a sospensione la fascia che tiene sospesa la lampada viene bloccata da un passante in metallo con finitura ottone satinato.

La collezione di lampade Xi comprende varie tipologie: lampada a sospensione, su barra orizzontale e non, lampada da terra a braccio e lampada da tavolo.

Nella versione sospesa, disponibile in più combinazioni di lampade singole o multiple, le lampade Xi vengono installate su una barra orizzontale ad altezza regolabile in finitura canna di fucile opaca, i cavi elettrici in finitura nera. La struttura a binario della barra permette di muovere orizzontalmente le lam-

pade e di fissarle nella posizione desiderata. Nella versione da tavolo il corpo illuminante è una lanterna grande posizionata su una base in metallo con finitura ottone naturale. La fascia in cuoio Saddle Extra sostiene la lampada e funge da maniglia per lo spostamento della lampada.

La versione Lampada a braccio da terra è composta da una singola lanterna sospesa, tipologia Extra Large. L'asta di sostegno è in acciaio satinato brunito. La fascia in cuoio Saddle Extra a cui è agganciato il corpo illuminante prosegue fino al basamento, rivestendo la parte posteriore del montante in acciaio. Il basamento è formato da una base circolare in marmo Nero Marquina semilucido, sormontato da uno zoccolo di bilanciamento in metallo. La versione Sospensione Extra Large è composta da una singola lanterna di dimensione extra large, sospesa tramite una fascia in cuoio Saddle Extra.

# A—G

## Alma — Table lamp



## Fede — Lamp

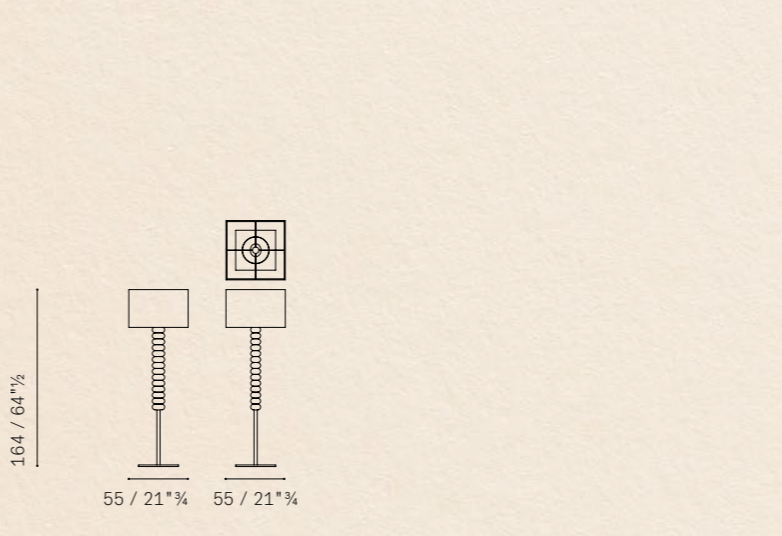

## Foliage — Lamp

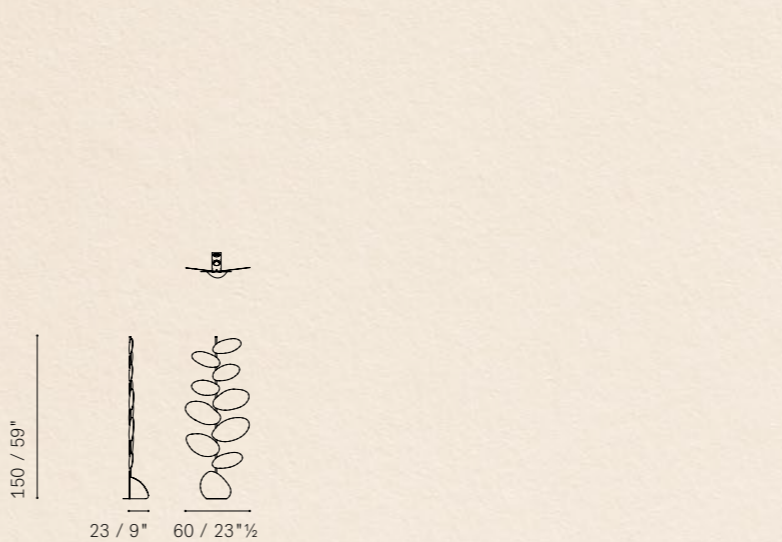

Please note:  
this catalogue shows only some technical drawings, in order  
to know all the availabilities please refer to the current price list.

## Dido — Table Lamp

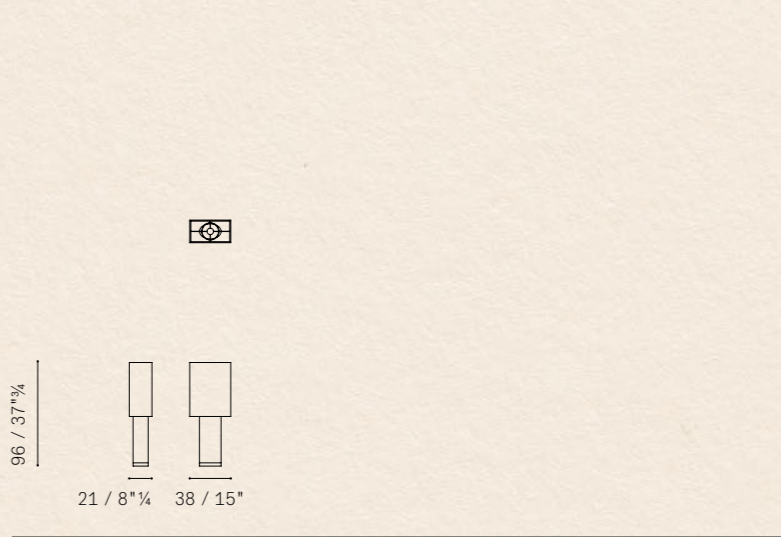

## Fidelio Lamp — Floor lamp

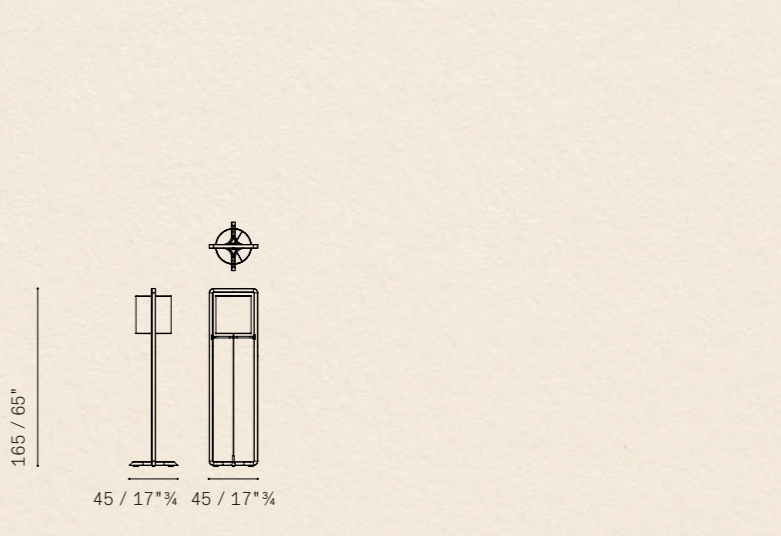

## Gio Ponti Oro — Floor Lamp



# H-S

Holly — Lamp

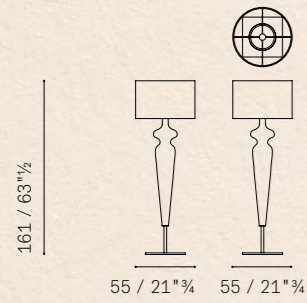

Holly — Table Lamp

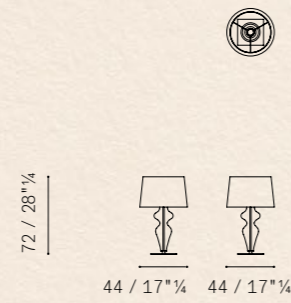

Moonbeam — Lamp

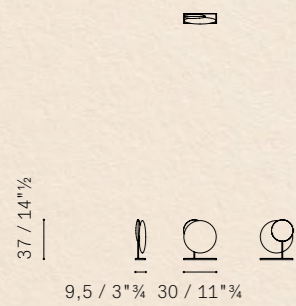

Moonbeam — Large Table lamp

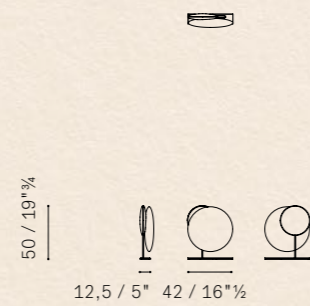

Moonbeam — Floor Lamp

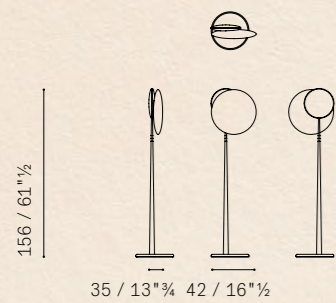

Nymph — Small Table lamp



Please note:  
this catalogue shows only some technical drawings, in order  
to know all the availabilities please refer to the current price list.

Nymph — Medium Table lamp

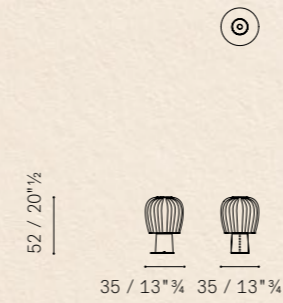

Nymph Air — Pendant lamp

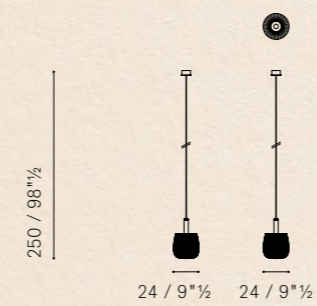

Soffi — Chandelier

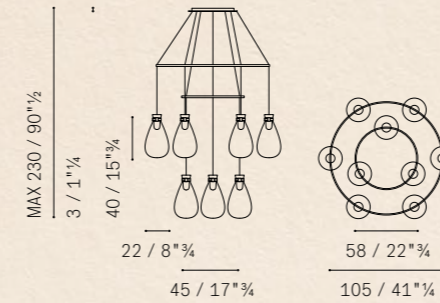

Nymph — Floor lamp

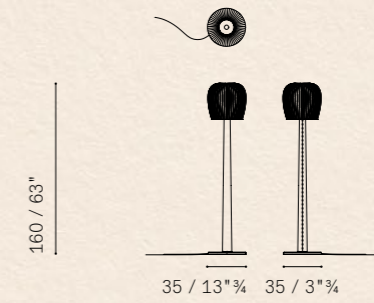

Nymph Air — Medium pendant lamp

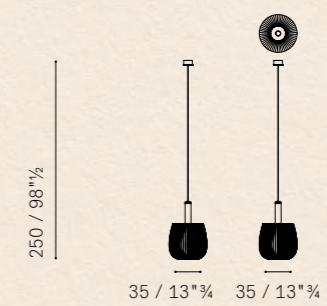

Soffi — Chandelier no. 18 medium lamps

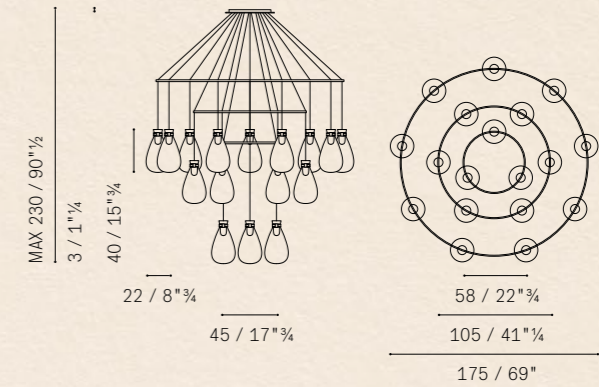

# S

Soffi — Chandelier

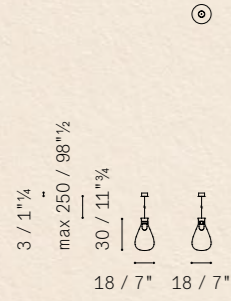

Soffi — Chandelier no. 18 medium lamps

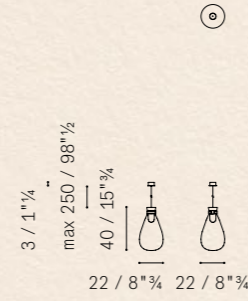

Soffi — Chandelier

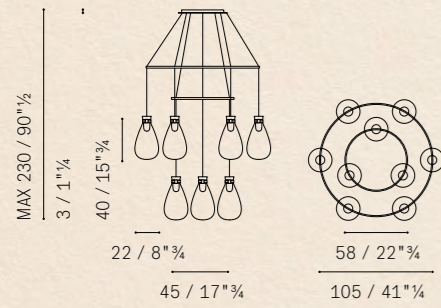

Soffi — Chandelier no. 18 medium lamps

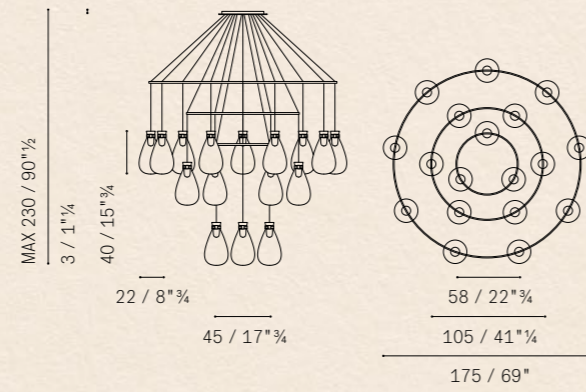

Soffi — Chandelier

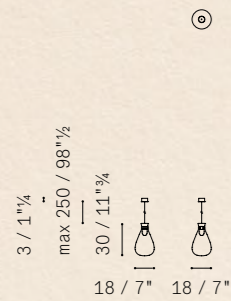

Soffi — Chandelier no. 18 medium lamps

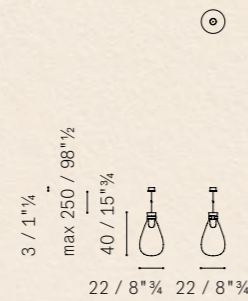

Please note:  
this catalogue shows only some technical drawings, in order  
to know all the availabilities please refer to the current price list.

Soffi — Chandelier

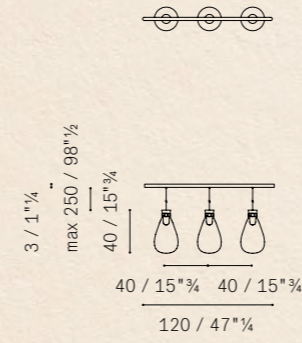

Soffi — Chandelier

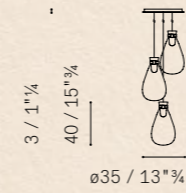

Soffi — Chandelier

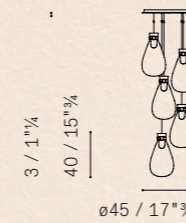

Soffi — Chandelier no. 18 medium lamps

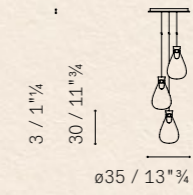

Soffi — Chandelier no. 18 medium lamps

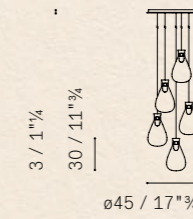

Soffi — Chandelier no. 18 medium lamps

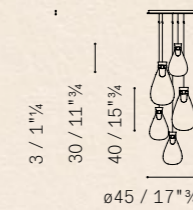

# S-X

Sparkler — Small lantern

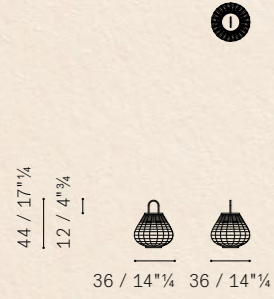

Sparkler — Medium lantern

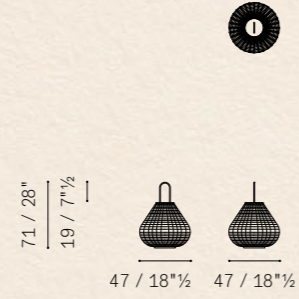

Sparkler — Large lantern

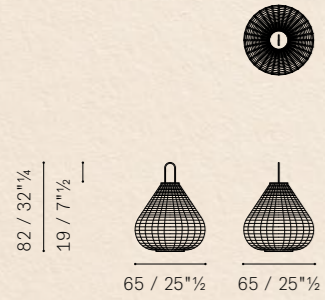

Sparkler — Suspension kit

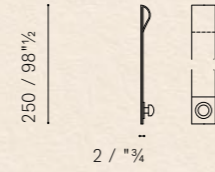

Sparkler — Floor suspension kit

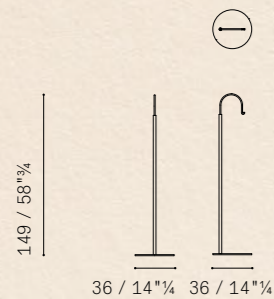

Configuration example

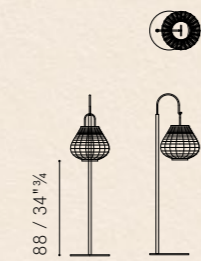

Please note:  
this catalogue shows only some technical drawings, in order  
to know all the availabilities please refer to the current price list.

Tullissè — Lamp

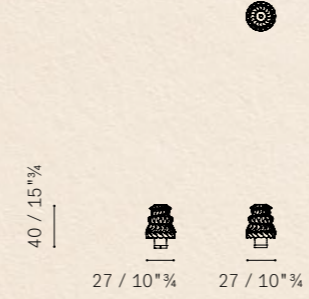

Xi — XL suspension lamp

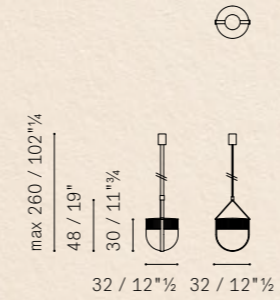

Xi — Lamp

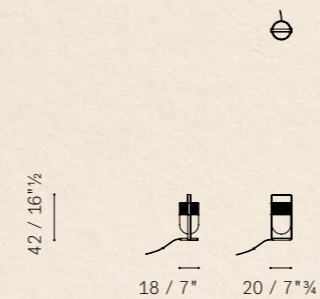

Tullissè — Large lamp

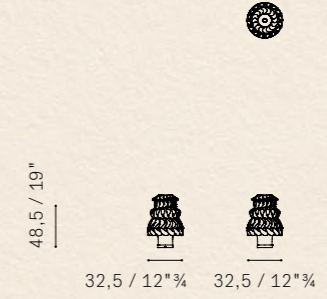

Xi — Floor arm lamp

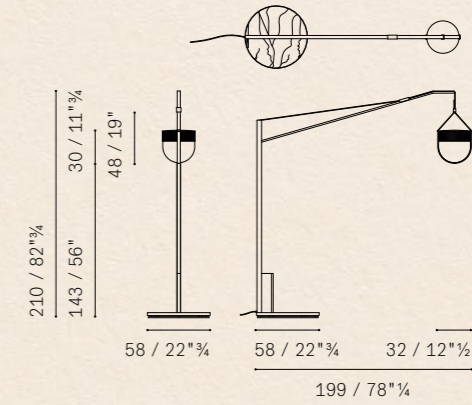

Xi — Lamp

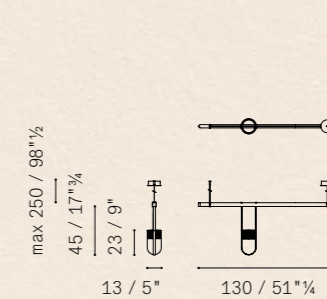

# X

Xi — Lamp

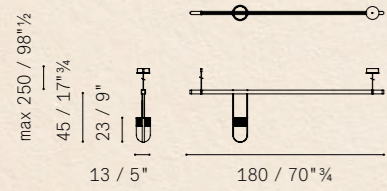

Xi — Lamp

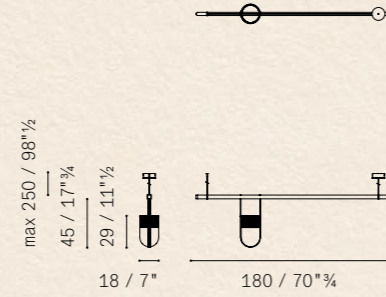

Xi — Lamp

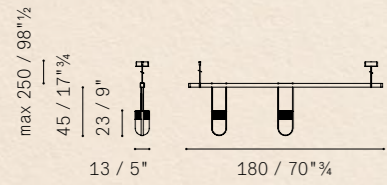

Xi — Lamp

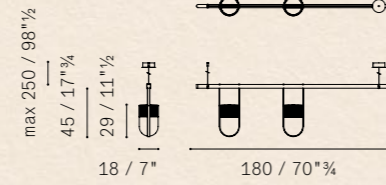

Xi — Lamp

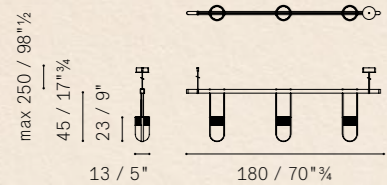

Xi — Lamp

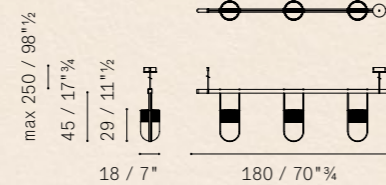

Please note:  
this catalogue shows only some technical drawings, in order  
to know all the availabilities please refer to the current price list.

Xi — Lamp

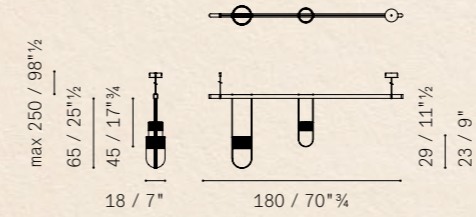

Xi — Lamp

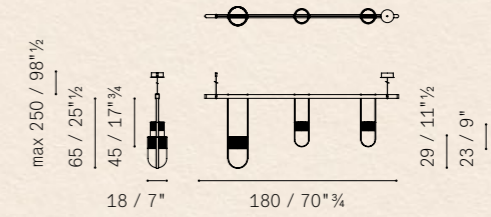

#### CONTACTS

##### **Poltrona Frau S.p.A**

a socio unico

Sede legale in Meda (MB)

Via Luigi Busnelli 1

20821 Italy

Sede operativa in Tolentino (MC)

Via Sandro Pertini 22

62029 Italy

Tel. +39 0733 909.1

Fax +39 0733 971600

[www.poltronafrau.com](http://www.poltronafrau.com)

#### CREDITS

Art direction / Graphic design

**studio FM milano**

Lifestyle CGI Photography

**Fuorifuoco agency**

Lifestyle Photography

**Adriano Brusaferrì**

**Bianca Puleo**

**Alessio D'Aniello**

**Yumpu Cai**

Still-life Photography

**Alessio D'Aniello**

Post production / Color selection

**Pan Group Milano**

Printing

#### © POLTRONA FRAU 2025

Poltrona Frau reserves the right to modify the products and the components in this price list, without any prior notice.

Company with certified Quality Management System in accordance with ISO 9001, certified Environmental Management System

in accordance with ISO 14001, certified Occupational Health and Safety Management System in accordance with BS OHSAS 18001, certified Chain of Custody System in accordance with Forest Stewardship Council® FSC-STD-40-004 (FSC-C153281).

Company subject to management and co-ordination of Haworth Italy Holding S.r.l.



